

REVISION RECORD			
REV.	CONTENT	MOD.	DATE
^	初版发行		

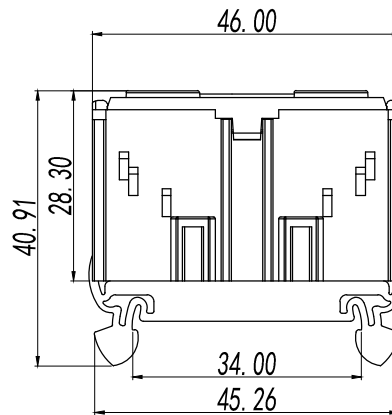
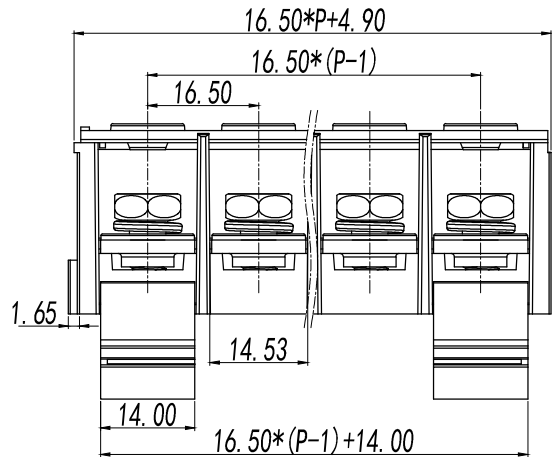
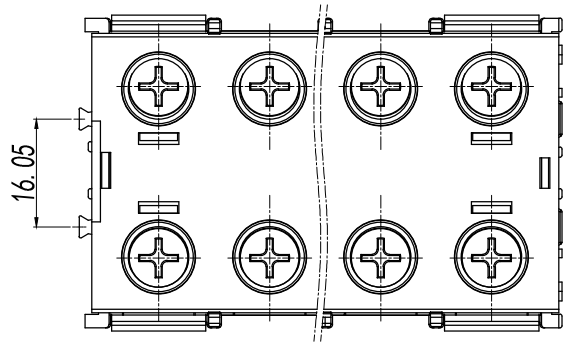

NOTES:
 Pitch : 12.0mm
 Rated Voltage : 600V
 Rated Current : 60A
 Withstand Voltage :
 AC3000V for 1 minute
 Insulation Resistance :
 1000MΩ / DC500V
 Using Temperature Range :
 - 40°C ~ + 105°C
 Suitable Electric Wire: 22-8 AWG
 Screw Torque Value : M6/2.5Nm

技术要求:
 间距: 12.0mm
 额定电压: 600V
 额定电流: 60A
 耐电压值: AC3000V/min
 绝缘阻抗: 1000MΩ/DC500V
 使用条件: -40°C~+105°C
 适用线规: 22-8 AWG
 螺丝扭矩: M6/2.5Nm

	pitch dimension			Nominal dimension					— ▱ ⤴
	over 0	over 6	over 10	over 0	over 30	over 60	over 100	over 150	
variable range	to 6	to 10	to 24	to 30	to 60	to 100	to 150		
Tolerance	±0.1	±0.15	±0.25	±0.2	±0.3	±0.5	±0.7	±1.0	0.05/10

7	DG-L-C45/2米	6JH9LDG0001V	1	铝	
6	KJ44-卡脚	6TB1J300653V	2	PA66-V0	黑色
5	标记条		1	A4腹膜纸	
4	6*12-14螺丝	6*12-14螺丝	2*P	碳钢	三价五彩
3	TA-40A-C导电件	6TB1BDD040AV-1	P	黄铜	镀镍
2	TB1-60-H盖板	6TB1C306050V-H	1	PC	透明
1	TB1-60-H主体	6TB1E306050V-H	1	PC	黑色
NO.	NAME OF PART	NO. OF PART	Q'TY	MATERIAL	NOTES
DES.	CMZ	DATE	2026/03/31	UNITS	mm
CHK.		DATE		SIZE	A4
APP.		DATE		SCALE	1:1
				DWG NO.	SP-1-6TB1H60
				REV.	V0
 上海有乐电气有限公司 Shanghai YouLe Electric CO., LTD				TITLE	TB1-60XX-H-1Y-00A
					TB1-60XX-H成品